

DS808

Datasheet

Applies to Part Number:

587860

Intellivox - DS808

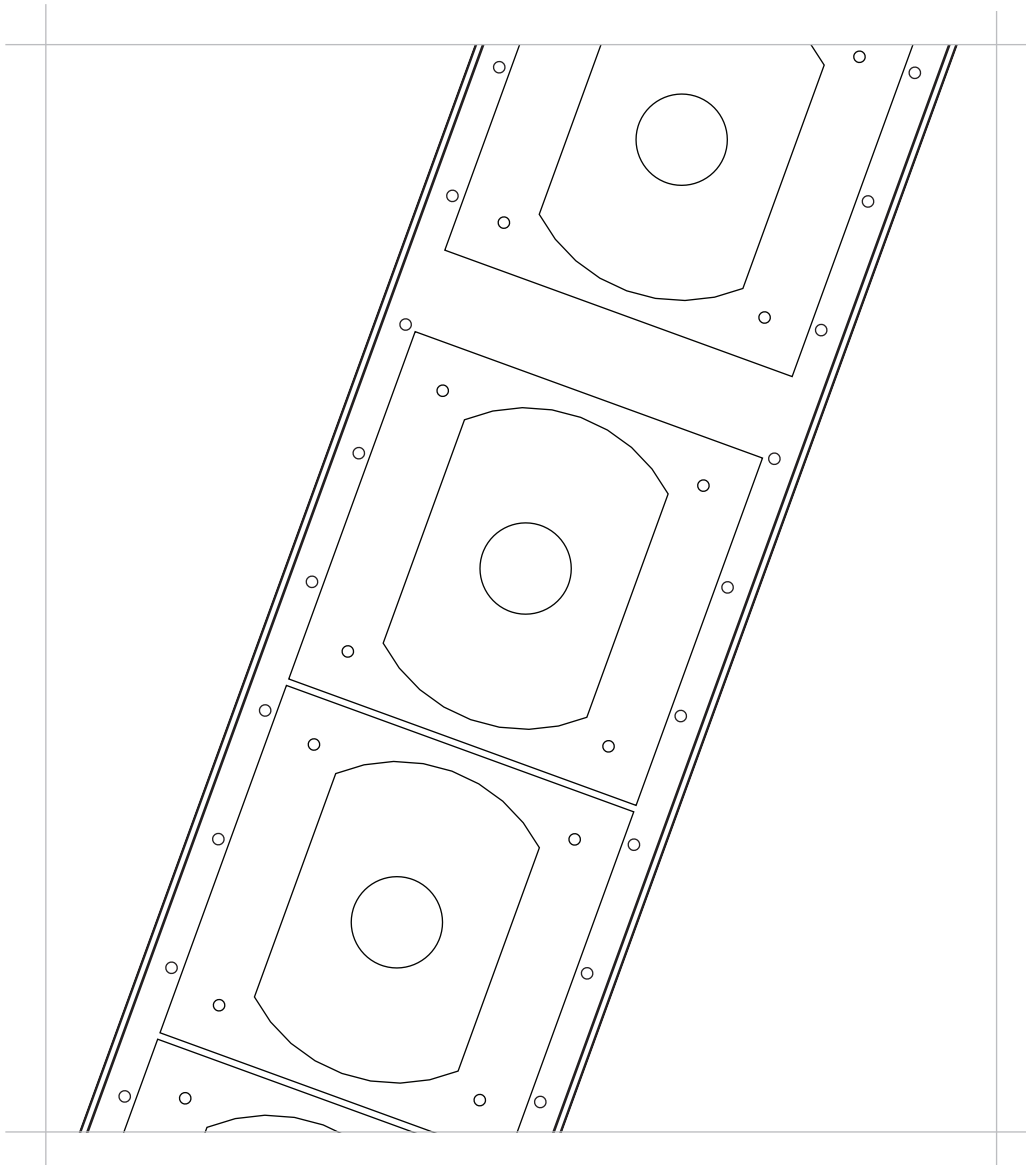

User Notice:

- No part of this document including the software described in it may be reproduced, transmitted, transcribed, stored in a database system or translated without the express written permission of Duran Audio BV. Documentation kept by the end-user for backup purposes is excluded from the above mentioned.
- All products and corporate names mentioned in this document may be registered trademarks or copyrights of their respective companies. They are used here for indicative purposes only.
- The information contained in this document has been carefully checked for accuracy, however no guarantee is given with respect to the correctness. Duran Audio BV accepts no responsibility or liability for any errors or inaccuracies that may appear in this document or the products and/or software described in it.
- Specifications and information contained in this document are subject to change at any time without notice.

Table of Contents

1. Architectural and engineering specifications	4-5
2. Specifications	6-7
3. Mechanical details	8-9
4. Optional Accessories	10
5. DSP block diagram	11

1. Architectural and engineering specifications

The loudspeaker unit shall be constructed as a line-array of six 6.5" loudspeakers and two coaxially mounted HF compression drivers. The position of the individual transducers shall be according to a special patented scheme.

All signal processing functions, necessary to properly drive a directivity controlled line-array with electrical aiming properties, shall be housed in a separate 19" electronics module.

Electronics shall consist of an audio input module, two input / eight output channel DSP, eight power amplifiers with protection circuitry (each power amplifier shall drive one loudspeaker) and a switched-mode power supply. The input section shall be transformer balanced. All necessary array signal processing shall be implemented in the digital domain by means of a 900MFLOPS 32bits DSP. The DSP shall realize appropriate output channel filters and delays. Besides the aforementioned, the DSP shall be able to realize EQ, pre-delay,

volume and autogain, and compression as required. The DSP software and coefficients shall reside in non-volatile memory in order to facilitate adaptations and software updates.

The control unit shall be equipped with a fully isolated RS-485 based full-duplex serial network interface. This control unit shall serve three main functions:

- Remote monitoring of parameters like status of the DSP, amplifiers and loads, external pilot tone, status of the ambient noise sensing microphone, chassis temperature, ambient noise level, ambient temperature etc.
- Remote control of beam parameters, Input related parameters, volume, pre-delay, EQ, autogain configuration and surveillance related parameters.
- Updating DSP software and factory unit programming.

The amplifier unit shall be equipped with a 3p male Neutric Powercon mains supply connector. The audio signal shall be connected to a 6p male 5 mm pitch cage clamp connector (as WAGO series 231) or 3p XLR female connector. The RS-485 signal shall be connected to a 5p cage clamp connector (as WAGO series 231) or 5p XLR male / female connector. The loudspeaker connector shall be a 20p multipole connector (Harting HAN type).

The loudspeaker enclosure shall be constructed of steel finished with an epoxy coating. At the back side of the enclosure a total of two bracket attachment points shall be provided (located near the outer ends). The protective front shall consist of a perforated steel grill which can be clicked onto four snap-in studs mounted on the enclosure.

The complete loudspeaker unit shall meet the following criteria:

Typical frequency range of the complete array 130 - 18k Hz on axis (+/- 3 dB), max. SPL at 30 m of 95 dB_{SPL} continuous and 105 dB_{SPL} peak, adjustable vertical beam shape is defined by the DDS (Digital Directivity Synthesis) algorithm, fixed horizontal opening angle of 110° (-6 dB, averaged 1k to 8k Hz).

Dimensions are 1278 mm (50.3") H
x 198 mm (7.8") W x 156 mm (6.1") D.

Weight 37 kg (81 lbs).

The loudspeaker unit shall be the AXYS® model Intellivox-DS808.

2. Specifications

Acoustical:¹

Freq range ²	- 6.5" Loudspeaker - 1" Driver - Complete array	: 260 - 6k7 Hz (+/-3 dB) : 1k - 20k Hz (+3/-6 dB) : 130 - 18k Hz (+/-3 dB)
Max SPL ³	- Continuous - Peak	: 95 dB _{SPL} (A-weighed at 30 m) : 105 dB _{SPL} (A-weighed at 30 m)
Coverage	- Horizontal (fixed) - Vertical (adjustable) - Typical throw	: 110° (-6 dB, averaged 1k - 8k Hz) : defined by the DDS algorithm : 25 m
Dynamic range ⁴		: >100 dB

Electrical:

Input ⁵	- Nominal level - Maximum level - Type - Impedance (balanced)	: 0 dBV (RMS, line input) : +19 dBV (peak, line input) : dual line input, transformer balanced : 6k8
DSP module	- Type - Memory - AD - DA conversion: - Auxilliary processor - Sample rate - Signal processing ⁶	: floating point 900 MFLOPS 32 bits : 64 Mb SDRAM + 3 Mb non volatile : 24 bits sigma-delta 128 x oversampling : 200 nsec single cycle RISC : 48.8 kHz (default) : - 21 sec (pre-delay) + 2 x 10 sec (input channel delay) - equalizer and compensation filtering - compressor - volume - ambient noise level dependent gain adaptation ('fail-safe') - eight output filters + delay ringbuffers - dual input configuration
Control unit	- Network interface type - Maximum number of units ⁷ - Remote surveillance - Failure	: serial full-duplex RS-485, autoswitching 115k2, 57k6, 38k4, 19k2 baud, optically isolated : 126 units : - general status (DSP running, signal present etc.) - amplifier monitoring and load monitoring schemes - external pilot tone detection (20k - 30k Hz, level > -22 dBV) - external ambient noise microphone (optional) - frost protection - fan control for optional external fan - thermal overload protection : - internal hardware bypass circuit - failure relay (external connector, maskable conditions)
Power amps	- Type - Power - Protection	: MOSFET (class AB) : 8 x 100 W _{rms} (8) : - DC - Short Circuit

Connectors	- General type	: 5 mm pitch cage clamp (as WAGO series 231)	
	- Audio inputs (back) ⁸	: WAGO 6p male p1 = Line 1 +, p2 = Line 1 -, p3 = GND p4 = Line 2 +, p5 = Line 2 -, p6 = GND	
	- Audio inputs (front) ⁸	: XLR 3p male / female p1 = GND, p2 = Line 1 +, p3 = Line 1 -	
	-RS-485 interface (back) ⁹	: WAGO 5p male p1 = A, p2 = B, p3 = Z, p4 = Y, p5 = DGND	
	-RS-485 interface (front) ⁹	: XLR 5p male / female p1 = DGND, p2 = Y, p3 = Z, p4 = B, p5 = A	
	- Ambient noise and temp sensor	: WAGO 5p female p1 = MIC, p2 = AGND, p3 = NTC, p4 = AGND, p5 = GND	
	- Failure detect	: WAGO 5p female failure relay : p1 = COM, p2 = NO, p3 = NC reserved : p4 = -, p5 = +24 V	
	- Loudspeakers	: 20p Harting HAN 16 / STAF 20 female on amplifier unit* 20p Harting HAN 16 / STAF 20 male on loudspeaker unit*	
	- Default loudspeaker cable length	: 5 m	
	- Mains	: 3p male Neutric Powercon	
	PSU	- Mains voltage	: 90 to 270 V
		- Mains fuse(s)	: 1 x 6.3 A automatic fuse, manually resettable (slow type)
		- Power consumption ¹⁰	: 95 VA (idle) / 760 VA (full load)
- Power factor		: 0.80 (idle) / 0.86 (full load)	
- Max mains inrush current		: 20 A short-time peak (@ 230 V)	
- Protection		: - thermal protection - output current limiting - under-voltage and over-voltage lock out	

General:

Temperature range (ambient)	: 0 to 40 °C (32 - 104 °F)
Transducers	: 6 x 6.5" : 2 x 1" compression driver, coaxially mounted
Dimensions (HxWxD)	- Loudspeaker unit ¹¹ :1278 mm (50.3") x 198 mm (7.8") x 156 mm (6.1") - Amplifier unit ¹² :132 mm (5.2") x 483 mm (19") x 370 mm (14.6"), 19"3 HU
Default color	- Enclosure and grill : RAL 9010 (white) - Speaker baffle : RAL 9011 (black)
Weight	- Loudspeaker unit : 37 kg (81 lbs) - Amplifier unit : 13 kg (29 lbs)

Notes:

1. Measured outside under semi-anechoic 'full-space' conditions with typical filter and delay settings unless stated otherwise.
2. Single transducer data is determined from 1/3 octave averaged data measured on-axis. The frequency response of the complete array is depending on the actual signal processing parameters and air absorption (at larger distances). A typical bandwidth is specified for the complete array under 'full-space' radiation conditions.
3. Levels are valid for pink noise (100 to 20k Hz bandwidth) with a crest factor of 10 dB. Default EQ and minimum opening angle setting. 'Continuous' is the RMS level, 'Peak' is the absolute peak level, both determined at the onset of the output limiters.
4. For this measurement the signals at all power amplifier outputs are summed together. Measured as the A-weighted difference (in dB) between the maximum rms level (with pink noise input signal) and the noise output (with no input signal present).
5. Specs valid for default dual input board. An optional input board (part number 381001) with 1x line level input and 1x 100V input is available.
6. Additional processing capabilities available.
7. Maximum number that can be connected to one RS-485 subnet, multiple subnets can be controlled by one host PC.
8. WAGO connector located at the back of the amplifier unit, 3p XLR male and female connectors located at the front. All audio input connectors are hardwired linked.
9. WAGO connector located at the back of the amplifier unit, 5p XLR male and female connectors located at the front. All RS-485 connectors are hardwired linked.
10. Defined as the rms mains current multiplied by the rms mains voltage under normal operating conditions. 'Full load' figures are maximum values measured with a pulsating pink noise input signal.
11. Depth including mounting brackets / 1" drivers protection cover.
12. Dimensions of amplifier enclosure only, measured without connectors attached.

*Pinning reference for the Harting	
Channel	Pin #
1	1/11
2	2/12
3	3/13
4	4/14
5	5/15
6	6/16
7	7/17
8	8/18

3. Mechanical Details (part number 587860)

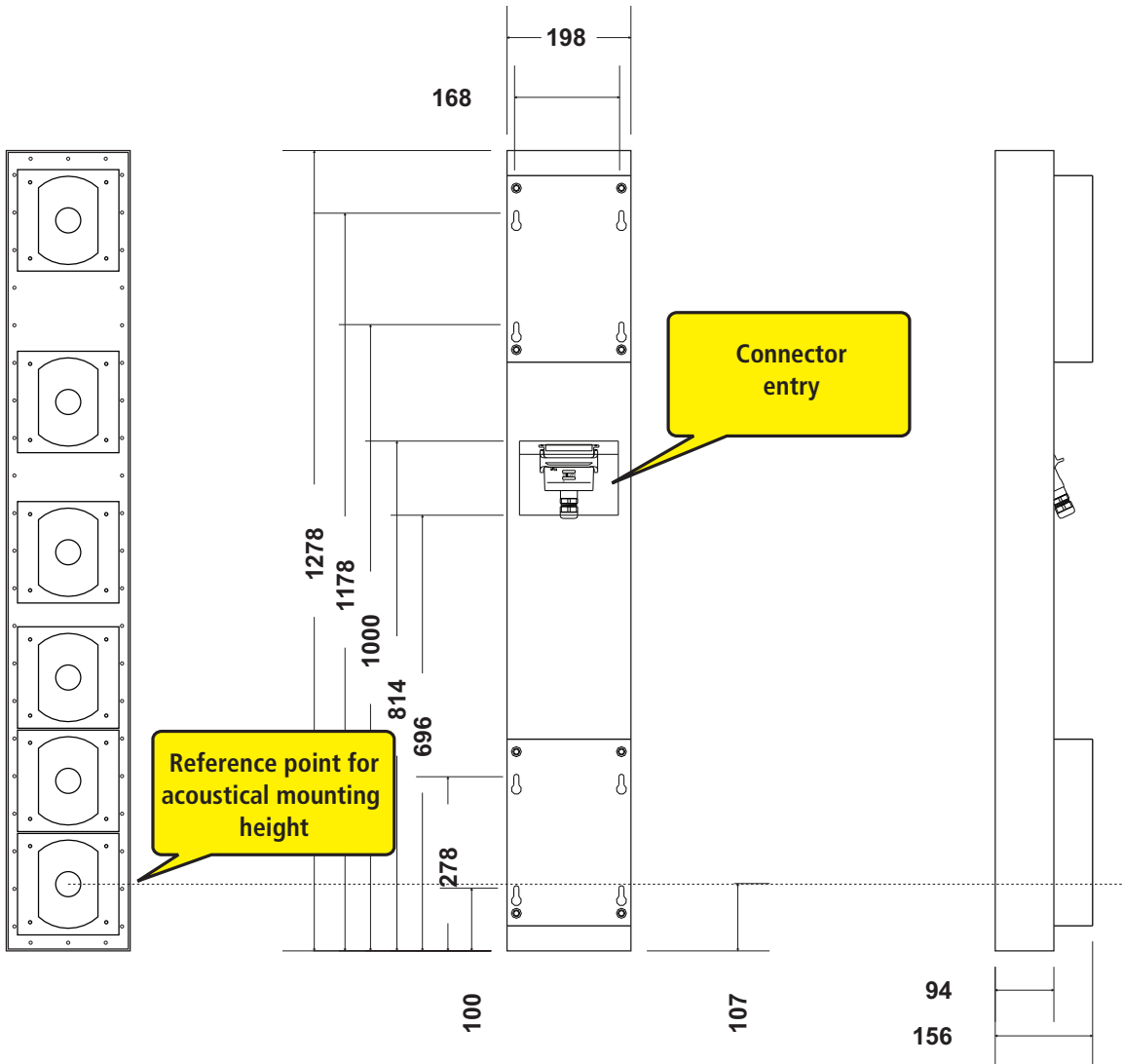

3. Mechanical Details (lvx-DS808 electronics module)

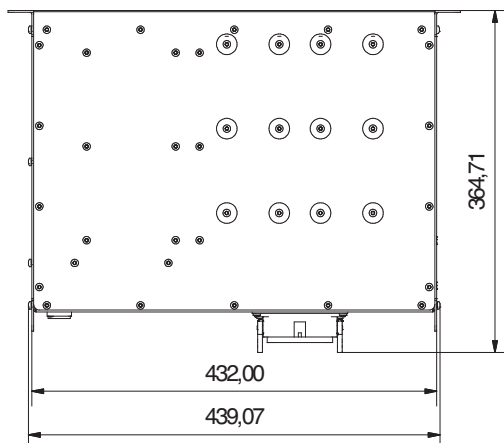
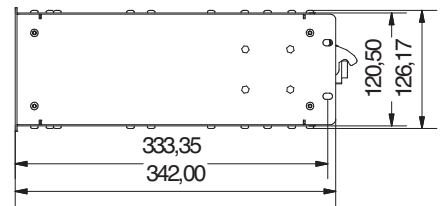
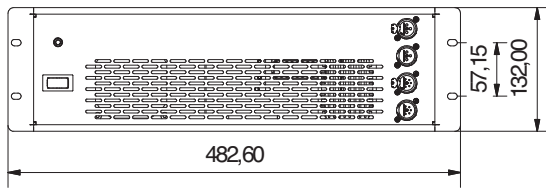
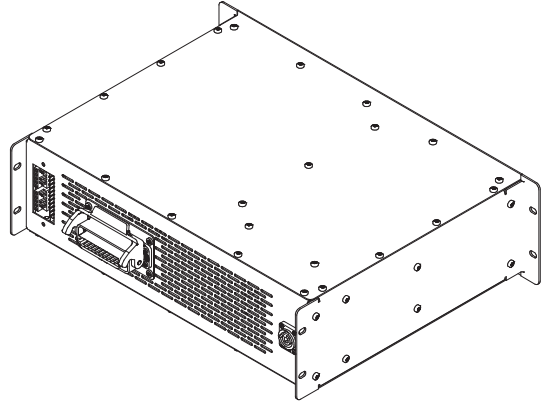
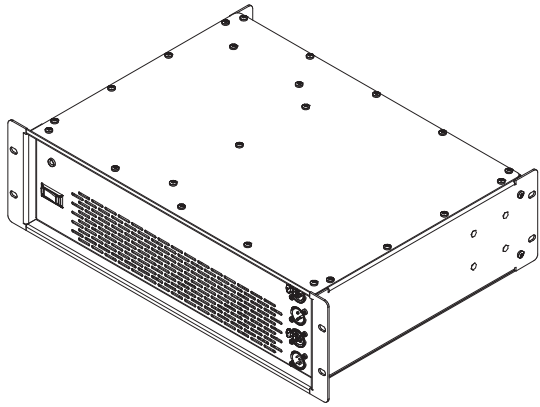

4. Optional Accessories

Hinge Bracket 90°

Order code: 802010

(1 pcs per pack)

Standard colour RAL 9010



Ambient Noise Microphone

and Temperature Sensor

Order code: 97661101



5. DSP Block Diagram

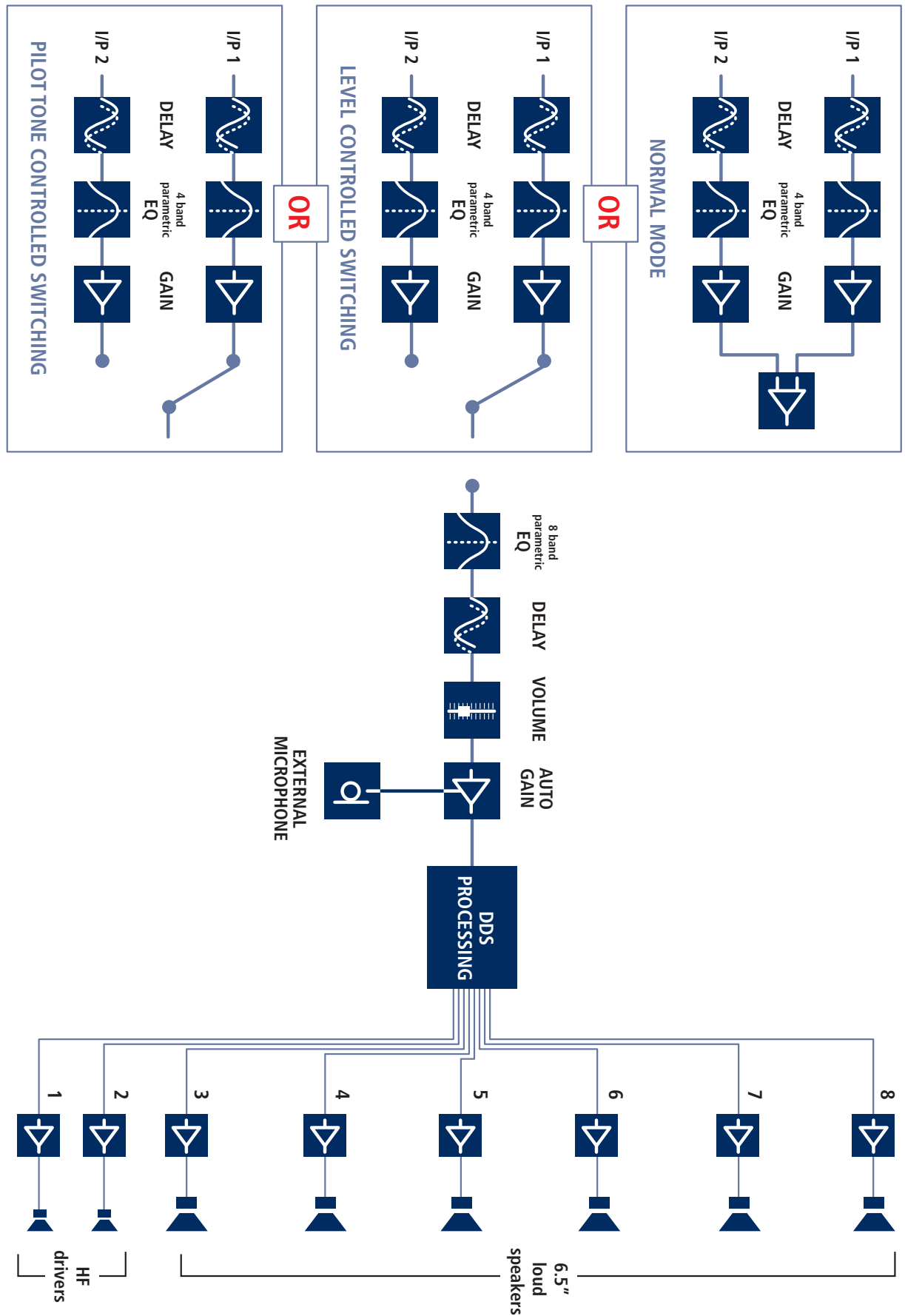



IS A REGISTERED TRADE MARK OF

DURAN AUDIO BV

Koxkampseweg 10, 5301 KK Zaltbommel, The Netherlands.

tel. +31 418 515583 fax. +31 418 518077

<http://www.duran-audio.com> Info@duran-audio.com